

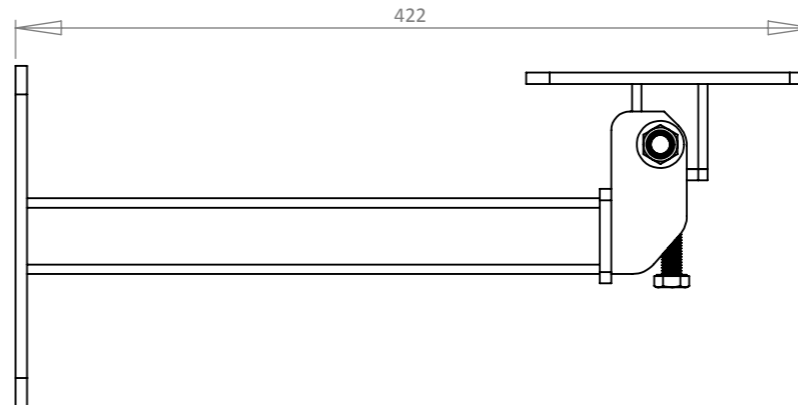

IF IN DOUBT ASK

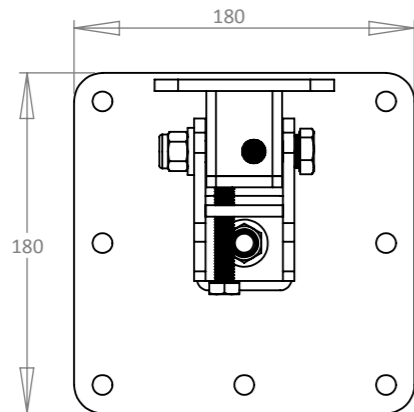
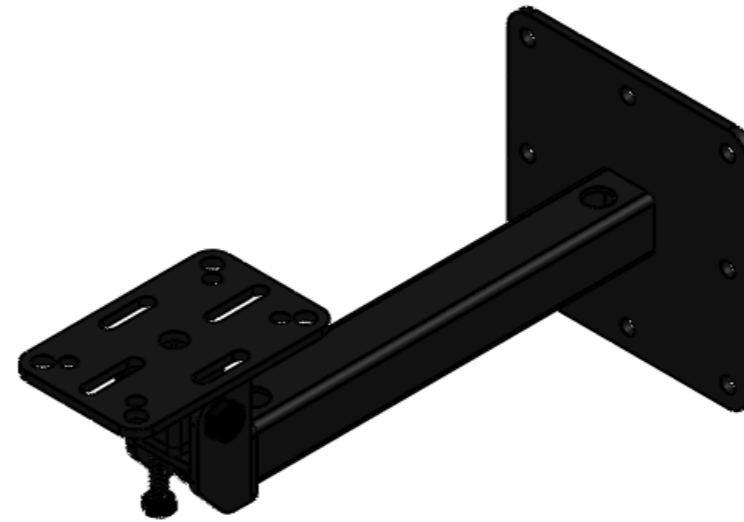
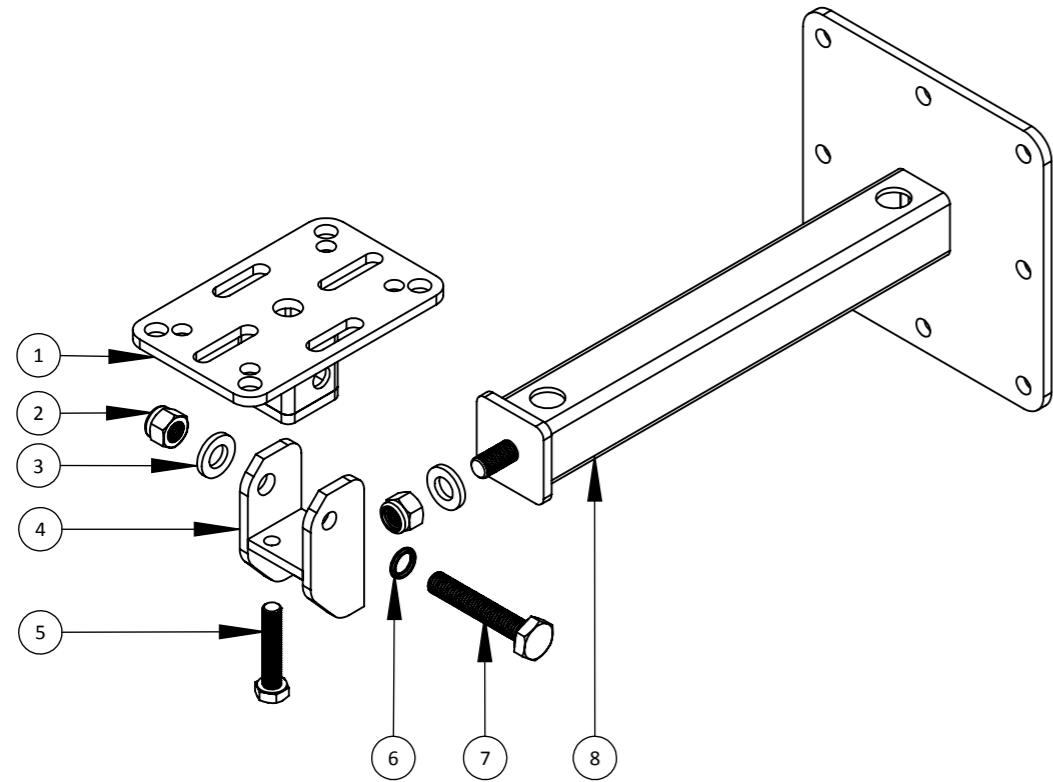

DEBUR AND BREAK SHARP EDGES		DO NOT SCALE DRAWING	
UNLESS OTHERWISE SPECIFIED: DIMENSIONS ARE IN MILLIMETRES TOLERANCES: LINEAR: xx ANGULAR: xx		TITLE: CMHB100-B	
MATERIAL: AS SHOWN		PART NO: CMHB100-B	
FINISH: AS SHOWN		Sheet 1 of 1	
WEIGHT: 512.01		SCALE: 1:4	A3
	NAME	SIGNED	DATE
DRAWN			
CHK'D			
APPV'D			
Comments:			
All rights reserved. This drawing and all information contained herein is the property of Powerdrive Drum Company Ltd and as such may not be copied or reproduced, in whole or in part, without prior written agreement.			

PART NO.	ITEM NO.	DESCRIPTION	QTY.
3011-304	1	Plate Type 100 Welded to 40mm Sq x 3mm Blanked M1234	1
1050-706		Plate 100 Type M817	1
1050-000		Plate Blanking 40mm Sq M1541	1
2040-705		Pillar Tilter 40mm Sq x 3mm M688	1
7011-400	2	Nut M12 Nylon Insert Thin Type B360	2
7041-400	3	Washer M12 Thick Type B328	2
3021-500	4	Swivel & Tilt Unit HD Inverted ST106	1
1000-201		Angle Component 40mm x 40mm x 6mm M10 TC M101	1
1050-600		Plate Side H/D Swivel & Tilt Unit M1177	1
1050-601		Plate Side H/D Swivel & Tilt Unit M12	1
7031-353	5	Set Screw M10 x 50mm Hex Head B312	1
7041-401	6	Washer M12 Spring Sq Section B222	1
7031-374	7	Set Screw M12 x 70mm Hex Head B352	1
3001-200	8	Arm HD Ceiling Drop C140	1
1050-201		Plate Ceiling 180mm Sq M1296	1
2040-800		Tube Drop 40mm x 40mm M1127	1
1050-001		Plate Blanking 50mm Sq x 6mm M1472	1
7031-370		Set Screw M12 x 30mm Hex Head B362	1